

Model CDUP Series

Compression Load Cell
Specially Designed
For Truck Scales (15t~ 25t)

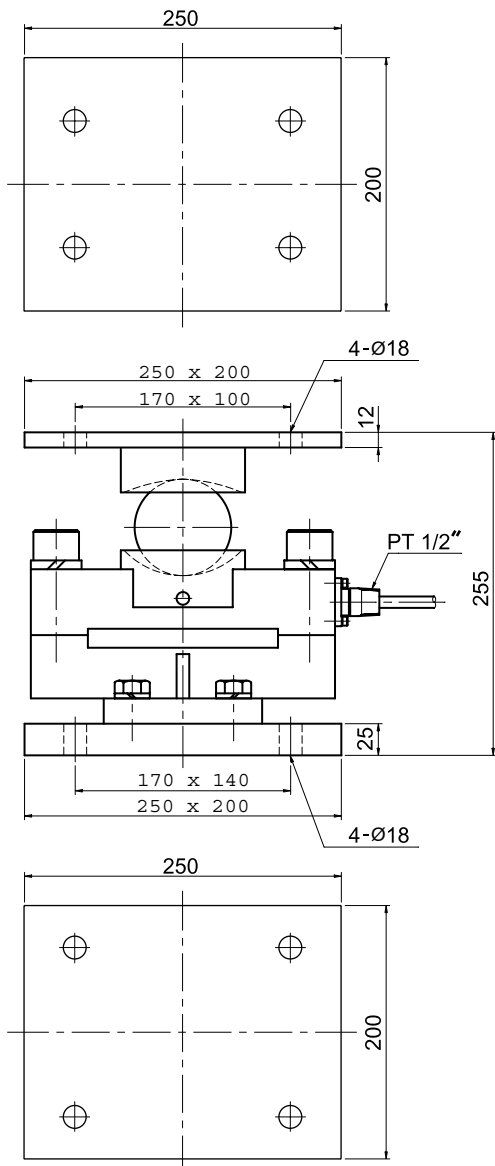
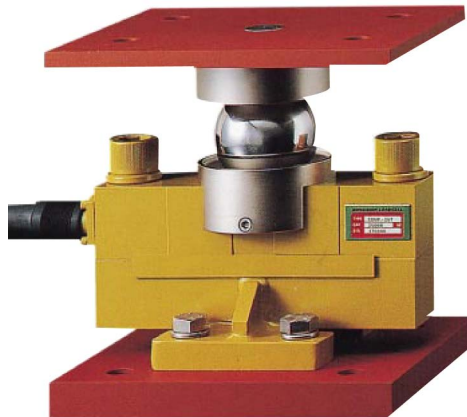

The model of CDUP is specially designed for truck and railroad scales in harsh environments. The effective integration of the CDUP mount and double ended shear beam load cell eliminates the need for troublesome check roads, links, expansion assemblies and other peripheral hardware.

The unique spherical ball point loading mechanism makes lateral movement of the assembly possible, while controlled floating of the scale deck is allowed.

High alloy tool steel load cell offers superior corrosion protection with waterproof potting.

- High overload tolerance
- Self centering design
- Electroless nickel plated alloy tool steel
- 0.02% accuracy
- Protection against harsh environment

SPECIFICATIONS

MODEL	CDUP
Rated capacity (R.C.)	15, 25t
Rated output(R.O.)	2.0mV/V ± 0.15%
Non-linearity	≤0.02% R.O.
Hysteresis	≤0.02% R.O.
Non-repeatability	≤0.02% R.O.
Creep error	≤0.03% in 20min.
Zero balance	≤1% R.O.
Compensated temperature range	-10 ~ 70°C
Operating temperature range	-20 ~ 80°C
Temp. effect on rated output	≤0.02% LOAD/10°C
Temp. effect on zero balance	≤0.03% R.O./10°C
Terminal input resistance	800 Ohms ± 30 Ohms
Terminal output resistance	700 Ohms ± 5 Ohms
Insulation resistance (Min.)	2000 MOhms at 50V DC
Excitation voltage	10V(Recommended), 15V(Max.)
Electrical connection	Ø7mmx10m(22AWG x 4Core Shielded)
Protection class	meets IP 67
Safe overload	150% R.C
Ultimate overload	300% R.C

Weight : 33kg

ORDERING INFORMATION

CDUP - 25T

MODEL: CDUP
CAPACITY: 15, 25 ton

WIRING INFORMATION

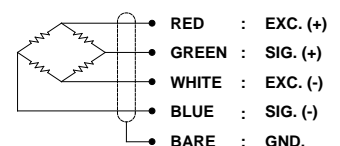

* Specifications are subject to change without notice

DEC, 2005